

THE LAST SUPPER ON THE MOON



NASA'S 1969 LUNAR VOYAGE, JESUS CHRIST'S BLOODY DEATH,
AND THE FANTASTIC QUEST TO CONQUER INNER SPACE

LEVI LUSKO

A PDF COMPANION TO THE AUDIOBOOK

All rights reserved. No portion of this book may be reproduced, stored in a retrieval system, or transmitted in any form or by any means—electronic, mechanical, photocopy, recording, scanning, or other—except for brief quotations in critical reviews or articles, without the prior written permission of the publisher.

Published in Nashville, Tennessee, by W Publishing Group, an imprint of Thomas Nelson.

Published in association with the literary agency of Wolgemuth & Associates, Inc.

Cover photo by Riley Connell

Front matter schematics, diagrams in Chapter 8, and small lunar module icon appearing throughout the body text (outlined image placed at text breaks) created by Marcin Szpak.

Thomas Nelson titles may be purchased in bulk for educational, business, fundraising, or sales promotional use. For information, please email SpecialMarkets@ThomasNelson.com.

Unless otherwise noted, Scripture quotations are taken from the New King James Version®. Copyright © 1982 by Thomas Nelson. Used by permission. All rights reserved.

Scripture quotations marked BSB are taken from the Holy Bible, Berean Study Bible, BSB. Copyright © 2016, 2018 by Bible Hub. Used by permission. All rights reserved worldwide.

Scripture quotations marked CEV are taken from the Common English Bible. Copyright © 2011 Common English Bible.

Scripture quotations marked CEV are taken from the Contemporary English Version. Copyright © 1991, 1992, 1995 by American Bible Society. Used by permission.

Scripture quotations marked ESV are taken from the ESV® Bible (The Holy Bible, English Standard Version®). Copyright © 2001 by Crossway, a publishing ministry of Good News Publishers. Used by permission. All rights reserved.

Scripture quotations marked GNT are taken from the Good News Translation in Today's English Version—Second Edition. Copyright © 1992 by American Bible Society. Used by permission.

Scripture quotations marked KJV are taken from the King James Version. Public domain.

Scripture quotations marked MSG are taken from THE MESSAGE. Copyright © 1993, 2002, 2018 by Eugene H. Peterson. Used by permission of NavPress. All rights reserved. Represented by Tyndale House Publishers, a Division of Tyndale House Ministries.

Scripture quotations marked NIV are taken from the Holy Bible, New International Reader's Version®, NIV®. Copyright © 1995, 1996, 1998, 2014 by Biblica, Inc.® Used by permission of Zondervan. All rights reserved worldwide. www.zondervan.com. The "NIV" and "New International Reader's Version" are trademarks registered in the United States Patent and Trademark Office by Biblica, Inc.®.

Scripture quotations marked NASB are taken from the New American Standard Bible® (NASB). Copyright © 1960, 1962, 1963, 1968, 1971, 1972, 1973, 1975, 1977, 1995, 2020 by The Lockman Foundation. Used by permission. www.Lockman.org.

Scripture quotations marked NIV are taken from the Holy Bible, New International Version®, NIV®. Copyright © 1973, 1978, 1984, 2011 by Biblica, Inc.® Used by permission of Zondervan. All rights reserved worldwide. www.Zondervan.com. The "NIV" and "New International Version" are trademarks registered in the United States Patent and Trademark Office by Biblica, Inc.®.

Scripture quotations marked NLT are taken from the Holy Bible, New Living Translation. Copyright © 1996, 2004, 2015 by Tyndale House Foundation. Used by permission of Tyndale House Ministries, Carol Stream, Illinois 60188. All rights reserved.

Scripture quotations marked PHILLIPS are taken from The New Testament in Modern English by J. B. Phillips. Copyright © 1960, 1972 J. B. Phillips. Administered by The Archbishops' Council of the Church of England. Used by permission.

Scripture quotations marked TPT are taken from The Passion Translation®. Copyright © 2017, 2018 by Passion & Fire Ministries, Inc. Used by permission. All rights reserved. ThePassionTranslation.com.

All italics used in quoted Bible verses indicate emphasis added by the author.

Any internet addresses, phone numbers, or company or product information printed in this book are offered as a resource and are not intended in any way to be or to imply an endorsement by Thomas Nelson, nor does Thomas Nelson vouch for the existence, content, or services of these sites, phone numbers, companies, or products beyond the life of this book.

ISBN 978-0-7852-5288-7 (audiobook)

ISBN 978-0-7852-5287-0 (eBook)

ISBN 978-0-7852-6456-9 (IE)

Library of Congress Control Number: 2021945428

ISBN 978-0-7852-5285-6

Printed in the United States of America

22 23 24 25 26 LSC 10 9 8 7 6 5 4 3 2 1

BEFORE LIFTOFF

GLOSSARY OF TERMS

Here is a list of terms that will be helpful for you on your journey.

Wherever a pronunciation is not given for an acronym, the term is sounded out by letter.

abort: the unscheduled termination of a mission prior to its completion

Apollo: the program that resulted in American astronauts walking on the moon; twelve missions using three-man spacecrafts between 1968 and 1972, after Mercury and Gemini (Apollo 1 ended in tragedy with three astronauts dying. Four of the twelve flights tested the equipment. Six of the other seven flights landed on the moon.)

Apollo spacecraft: the CSM (command and service module) and LM (lunar module) when docked together

CapCom: capsule communicator

CM: command module; the part of the Apollo spacecraft that contained the crew during takeoff from and reentry to earth

Columbia: the name of the CM (command module) on Apollo 11

cryo: hydrogen and oxygen fuel stored at extremely cold temps

CSM: command and service module; two distinct units, the CM (command module) and the SM (service module), when connected together

Eagle: the name of the LM (lunar module) on Apollo 11

EECOM [pronounced *eecom*]: electrical, environmental, and consumables manager; MCC (Mission Control Center) engineer responsible for electrical, environmental, and communications in the CSM (command and service module), including cryogenic, fuel cell, and structural systems

EVA: extravehicular activity; also called a space walk

FDO [pronounced *fido*]: flight dynamics officer; a specialist in launch and orbit trajectories

flight controller: NASA personnel who oversee various aspects of a spaceflight in real time, interpreting telemetry at their stations in the MOCR (Mission Operations Control Room); they are involved before, during, and after the mission

flight director: manager of flight controllers; role in the MOCR (Mission Operations Control Room) is like a conductor of a symphony

g-force: the force exerted upon an object by gravity or in reaction to acceleration or deceleration

Gemini or Project Gemini: America's second human space program (after Mercury, before Apollo), which tested movements and maneuvers necessary to attempt Apollo; ten missions in a two-man spacecraft between 1965 and 1966

go/no go: the decision to continue to the next event or abort an activity

GNC: guidance, navigation, and controls system engineer; MCC (Mission Control Center) engineer responsible for managing propulsion, altitude control, guidance and navigation systems in the CSM (command and service module)

Guido or Guidance: MCC (Mission Control Center) specialist in navigation and computer software systems

JSC: Johnson Space Center in Houston, Texas

KSC: John F. Kennedy Space Center on Merritt Island, Florida

LES: launch escape system; the part of the rocket that can propel the astronauts and their capsule away from the launch vehicle or launchpad in the event of an emergency during takeoff or ascent

LM (pronounced *lem*): lunar module (originally called lunar excursion module); the part of the Apollo spacecraft that landed on the moon

MCC: Mission Control Center in Houston, Texas

Mercury or Project Mercury: America's first human space program involving a one-man spacecraft traveling to space and then into orbit (There were six missions on Redstone and Atlas rockets between 1961 and 1963.)

MOCR (pronounced *maker*): Mission Operations Control Room at the MCC (Mission Control Center) in Houston, Texas; front row of this room was nicknamed "the trench"

NACA: National Advisory Committee for Aeronautics; formed in 1915 and absorbed by NASA in 1958

NASA (pronounced *nasa*): National Aeronautics and Space Administration; created on October 1, 1958, to oversee US space exploration and aeronautics research; led by an administrator nominated by the president and confirmed by the Senate

pogo: a rapid up-and-down shaking of a rocket that, if not corrected, will cause failure

powered descent: a maneuver that involves firing thrusters to assist a spacecraft in landing on the surface of a planet or moon

reentry: when a spacecraft reenters the atmosphere after flying above it

retro: MCC (Mission Control Center) specialist in reentry trajectories

Saturn V: three-stage launch vehicle that transported the Apollo spacecrafts from the earth toward the moon and carried Skylab, the United States' first space station, into orbit (Thirteen were launched.)

SM: service module; the part of the Apollo spacecraft that contained the main engines and most of the consumables (oxygen, water, helium, fuel cells, and fuel) jettisoned before reentry

splashdown: the process of landing a spacecraft in the ocean using multiple sets of parachutes that slow it down before it hits the water

stage: a section of a rocket that contains an engine or group of engines; the stages usually separate from the rocket when they have used up their fuel

surgeon: directs medical activities during the flight and monitors the health of the astronauts via telemetry

TELMU (pronounced *telmu*): telemetry, electrical, and EVA (extravehicular activity) mobility unit officer; monitors LM (lunar module) electrical and environmental control systems

thrust: the force produced by the engines of a rocket or plane directed forward or upward

TLI: translunar injection; a maneuver to leave a parking orbit around the earth toward the moon

Tranquility Base: the name of Apollo 11's landing site on the moon

CAST OF CHARACTERS

Though not exhaustive, this list includes some of the people you will meet in this book. Feel free to refer back to it to keep who's who straight in your mind.

Alan Shepard: first American in space on Mercury-Redstone 3; grounded due to inner-ear ailment; became chief of the astronaut office; returned to flight as commander of Apollo 14

Charlie Duke: air force test pilot; CapCom (capsule communicator) during Apollo 11 moon landing; lunar module pilot on Apollo 16

Christopher Columbus Kraft Jr.: the original flight director; instrumental in developing the functionalities and procedures of Mission Control; at the helm of Mission Control from Mercury until the beginning of the Apollo program

Donald K. “Deke” Slayton: air force test pilot; Mercury astronaut grounded by a heart condition; became director of flight crew operations and was responsible for NASA crew assignments; returned to flight and was Apollo docking module pilot on the Apollo-Soyuz Test Project

Edward White II: air force test pilot; pilot on Gemini 4; made the first American EVA (extravehicular activity), or space walk, on Gemini 4 mission; command pilot on Apollo 1

Edwin “Buzz” Aldrin Jr.: air force pilot; first astronaut with a doctorate; nicknamed “Dr. Rendezvous”; pilot on Gemini 12; lunar module pilot on Apollo 11 (the first spaceflight to land humans on the moon)

Frank Borman: air force test pilot; command pilot on Gemini 7; commander on Apollo 8 (the Christmas flight)

Gene Cernan: pilot on Gemini 9; commander for Apollo 17; person who has walked on the moon most recently

Gene Kranz: air force pilot; long-standing NASA flight director throughout the space race; chief flight director for the Apollo 11 mission; wore iconic vests and flattop haircut

Jack Garman: computer engineer and specialist; part of Steve Bales’s “back room” support; enabled the Apollo 11 mission not to abort during the 1202 program alarm crisis by giving knowledge of NASA computer codes in split-second timing; chief information officer at JSC (Johnson Space Center)

James [Jim] Lovell Jr.: navy test pilot; pilot on Gemini 7; command pilot on Gemini 12; command module pilot on Apollo 8 (the Christmas flight); commander on Apollo 13; first person to fly to the moon twice

James Webb: NASA administrator during Mercury and Gemini programs

John Glenn: navy test pilot; first American to orbit the earth on Mercury-Atlas 6; became a national hero; after a political career, returned to space at age 77 as a payload specialist on STS-95, becoming the oldest person to fly in space at that time

Katherine Johnson: American mathematician and human computer; one of the many women who were a vital part of the space program and without whom NASA would not have been able to get off the ground; provided calculations of orbital mechanics that were indispensable from Mercury all the way through Apollo; of her computations John Glenn said before his mission, “If she says they’re good, then I’m ready to go.”

Michael Collins: air force test pilot; pilot on Gemini 10; command module pilot on Apollo 11 (the first spaceflight to land humans on the moon)

Neil Armstrong: civilian; NACA test pilot; command pilot on Gemini 8; commander on Apollo 11; first person to walk on the moon

Peggy Whitson: biochemist; flight engineer on STS-111; first female commander of the ISS (International Space Station) on Expedition 16; commander of Expedition 51; current record holder for most cumulative days (665) spent in space; at age 57, oldest woman to go to space at the time of her mission; chief of the Astronaut Office

President John F. Kennedy: effortlessly cool, beloved visionary leader who threw down the gauntlet of the moonshot; was in office during Project Mercury and was the friend of several astronauts; was tragically assassinated in November 1963 before the dream of the moon landing was realized

President Lyndon B. Johnson: sworn in as president after President Kennedy was assassinated in Dallas, Texas; under his presidency Congress appropriated funds to fulfill President Kennedy’s vision through Gemini and the beginning of the Apollo program

President Richard M. Nixon: president during the Apollo 11 moon landing; spoke to Neil Armstrong and Buzz Aldrin from the White House during their EVA and greeted them in person when they returned

Robert Goddard: father of modern rocketry; patented liquid-fueled and multi-stage rockets in 1914; postulated in 1920 that humans could reach the moon using rockets; was not recognized for his ideas or accomplishments in spaceflight until after he was dead

Roger Chaffee: navy pilot; pilot on Apollo 1

Shane Kimbrough: army helicopter pilot; mission specialist on STS-126; flight engineer on Expedition 49; commander of the ISS (International Space Station) on Expedition 50; commander of the NASA SpaceX Crew-2 mission (on which he flew with this book manuscript on a thumb drive)

Steve Bales: NASA engineer and flight controller; served as guido on Apollo 11

Virgil “Gus” Grissom: air force test pilot; pilot on Mercury-Redstone 4; command pilot on Gemini 4; commander on Apollo 1

Walter Cronkite: trusted CBS reporter whose narration was the soundtrack of the space race for the American people; known for his sign-off slogan, “And that’s the way it is.”

Wernher von Braun: German-born scientist who designed rockets in Germany during WWII; developed rockets for America’s space program, most notably the Saturn V used in the Apollo moon landings

William [Bill] Anders: air force pilot; lunar module pilot on Apollo 8 (the Christmas flight)

SATURN V

HEAVY LAUNCH VEHICLE

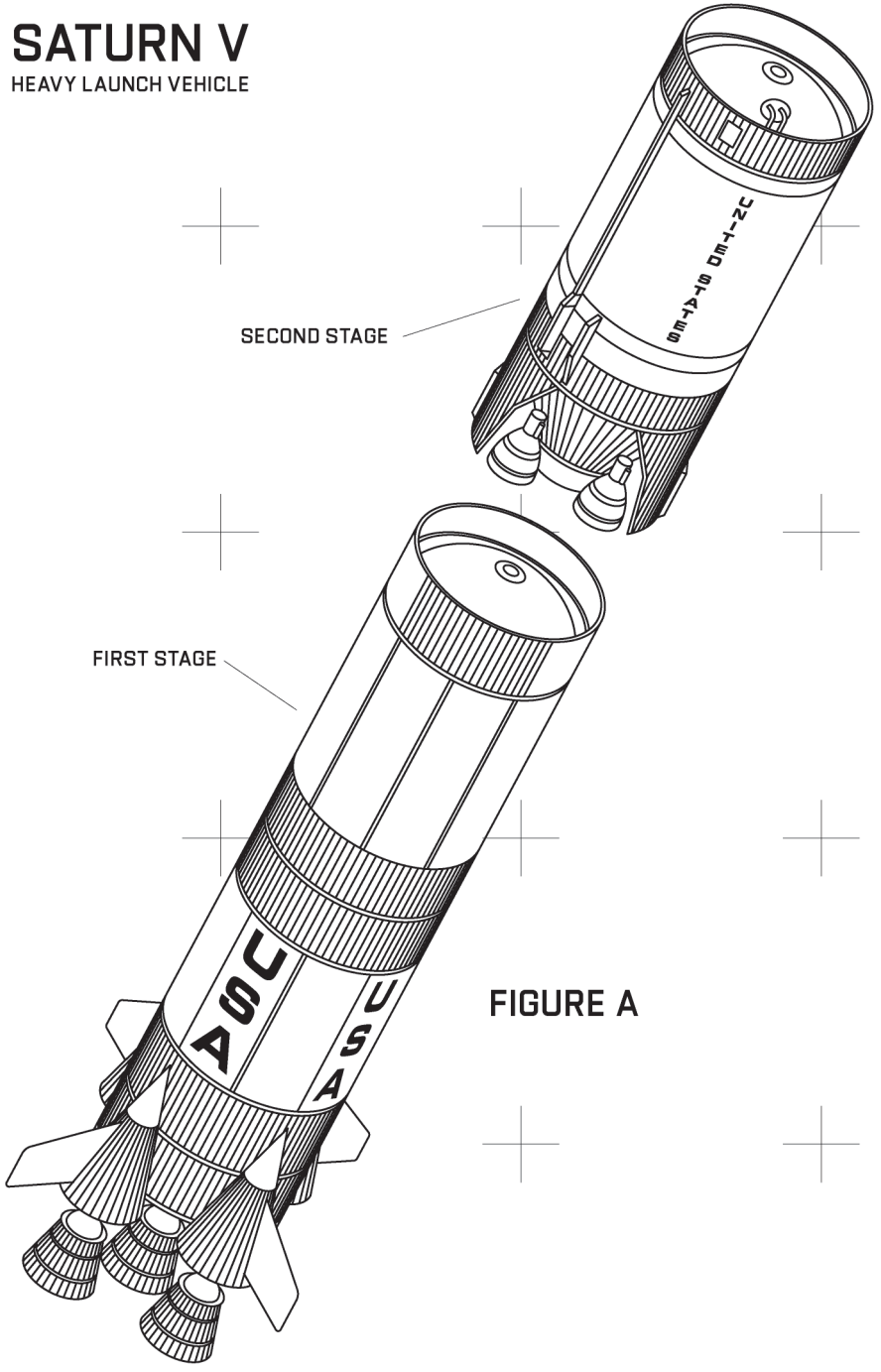
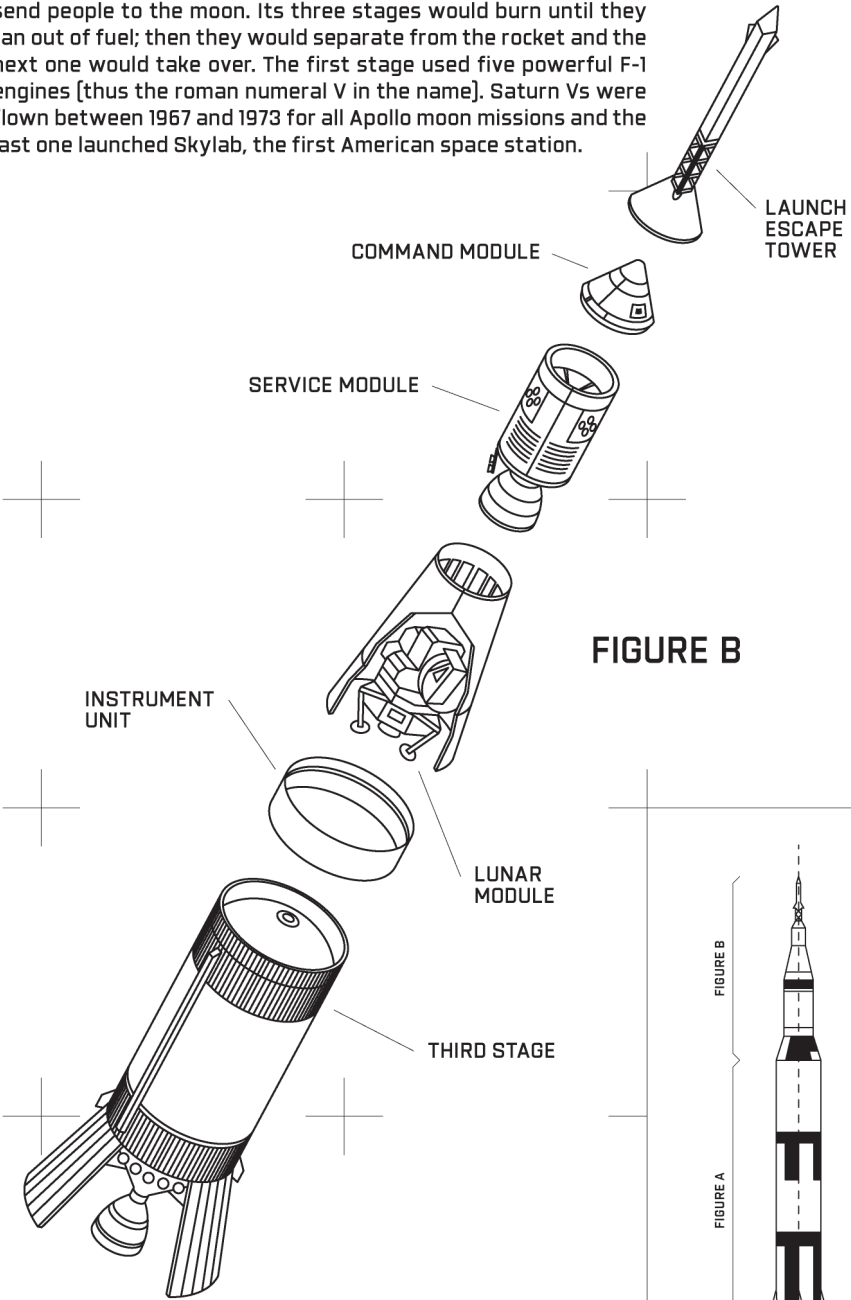

FIGURE A

Saturn V was a powerful three-stage rocket built by NASA to send people to the moon. Its three stages would burn until they ran out of fuel; then they would separate from the rocket and the next one would take over. The first stage used five powerful F-1 engines (thus the roman numeral V in the name). Saturn Vs were flown between 1967 and 1973 for all Apollo moon missions and the last one launched Skylab, the first American space station.



APOLLO MISSION PROFILE

THE EAGLE HAS LANDED...

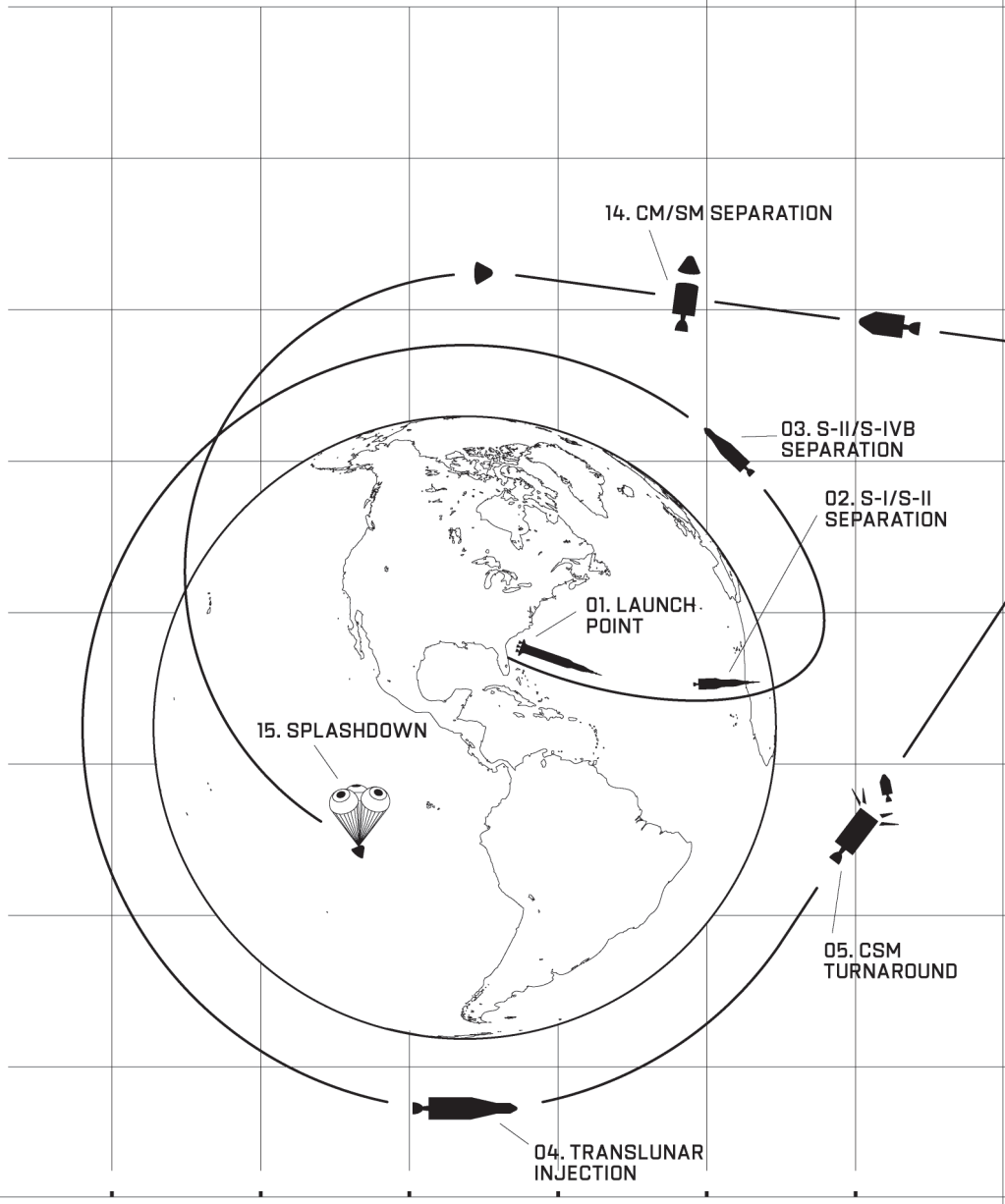

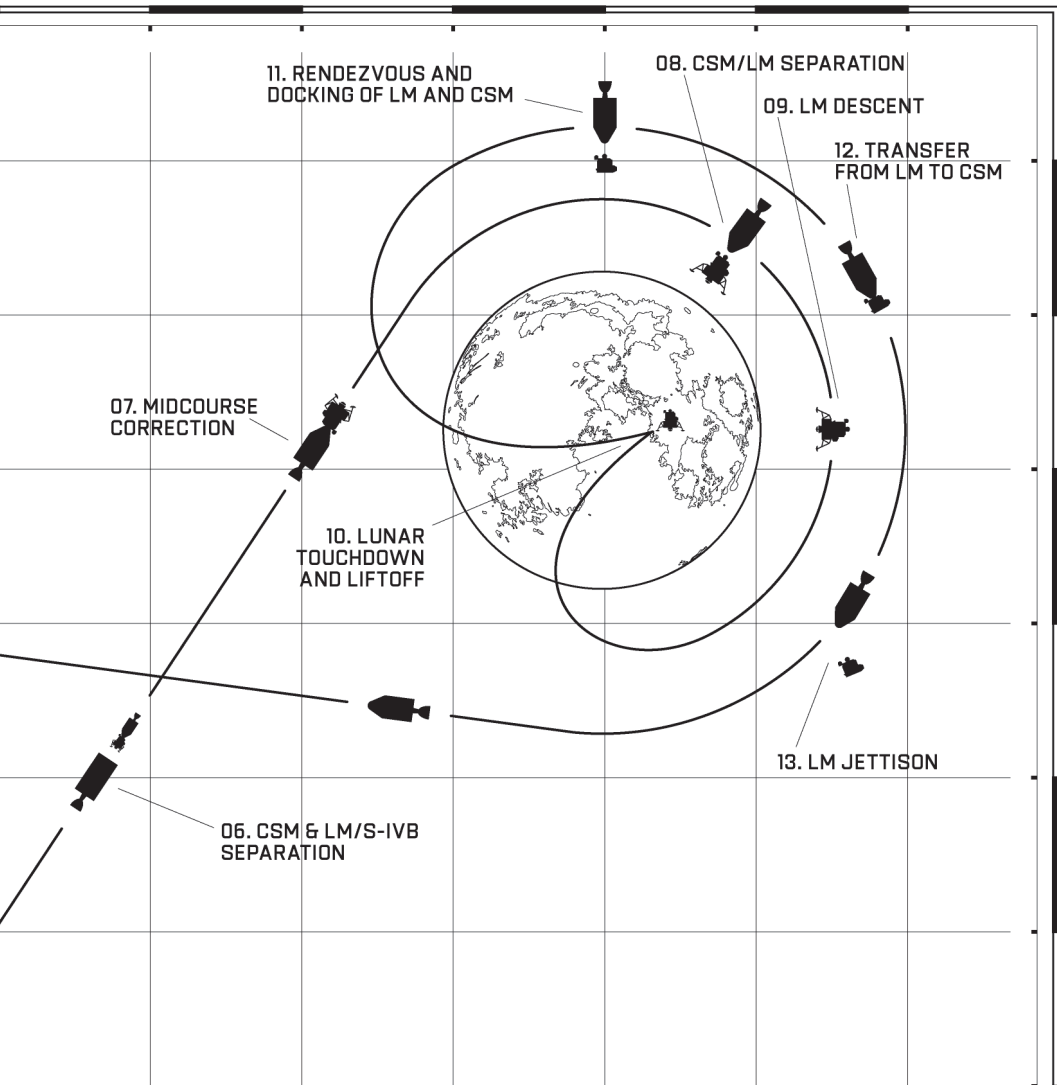

The mission objective of Apollo 11 was to land a manned spacecraft on the moon and return to earth. This would meet a national goal for the sixties as set by President John F. Kennedy on May 25, 1961.

APOLLO SPACECRAFT

THE PAYLOAD

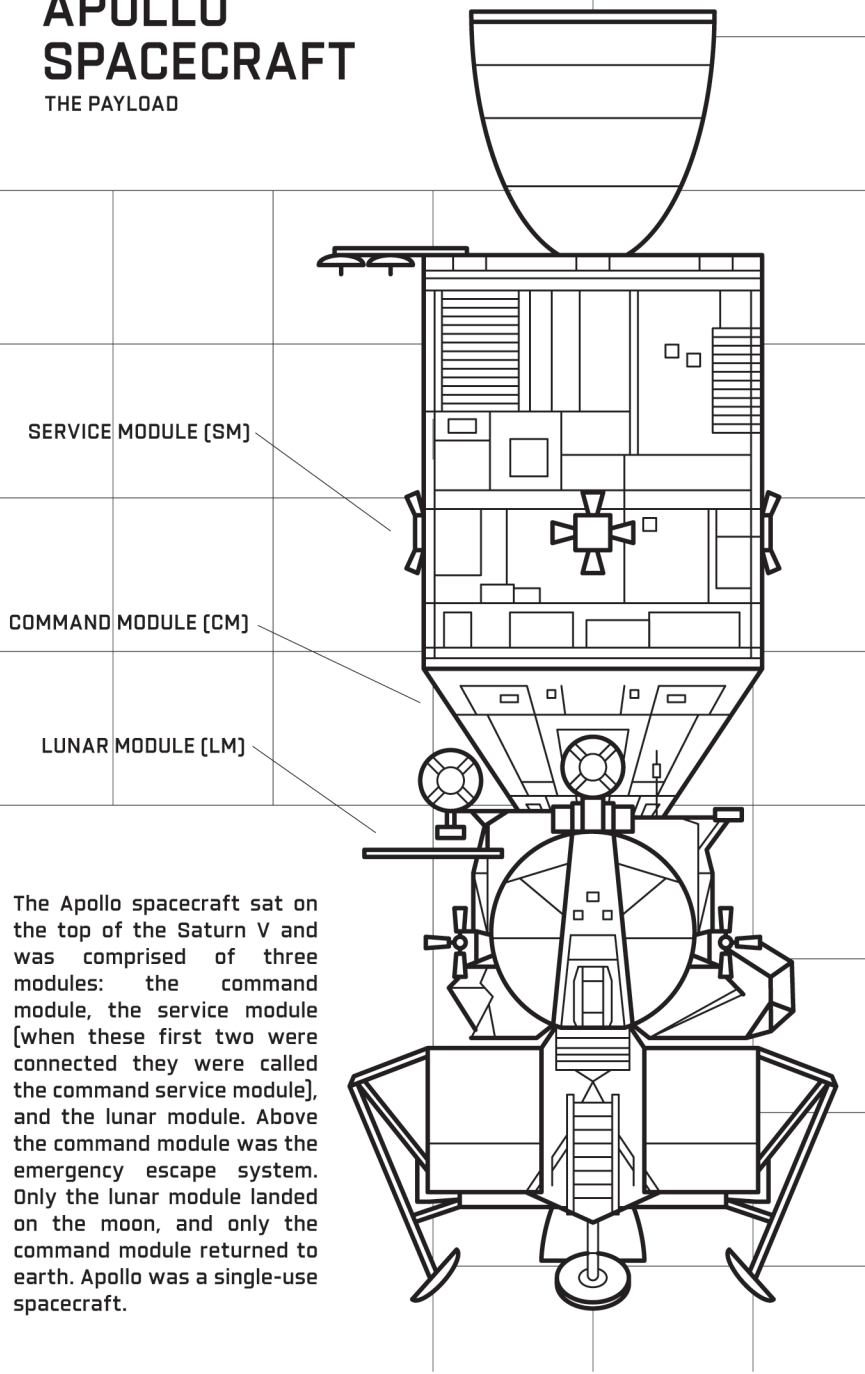

The Apollo spacecraft sat on the top of the Saturn V and was comprised of three modules: the command module, the service module [when these first two were connected they were called the command service module], and the lunar module. Above the command module was the emergency escape system. Only the lunar module landed on the moon, and only the command module returned to earth. Apollo was a single-use spacecraft.

TRANSPPOSITION, DOCKING, AND EXTRACTION

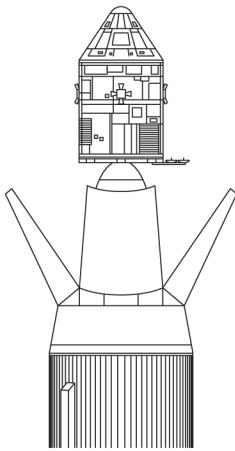

CSM SEPARATION

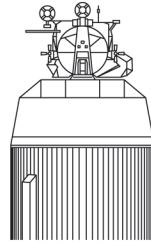
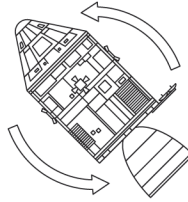

FREE FLY-AROUND

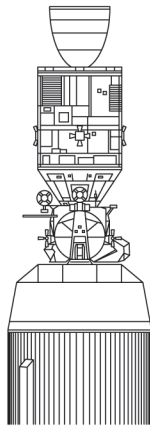

DOCKING

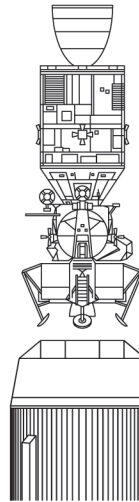

LM SEPARATION FROM
S-IVB

Like a scene from a James Bond movie, the command service module separated from the third stage of the Saturn V rocket [S-IVB] three hours and seventeen minutes after launch. Then it spun around and docked nose to nose with the lunar module, which had been stored in a compartment behind four silver petals that had fallen away. Once they were docked, the LM was released from the third stage and the LM and CSM merged into the Apollo spacecraft.

SEVEN CHURCHES OF REVELATION

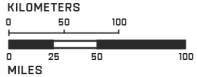
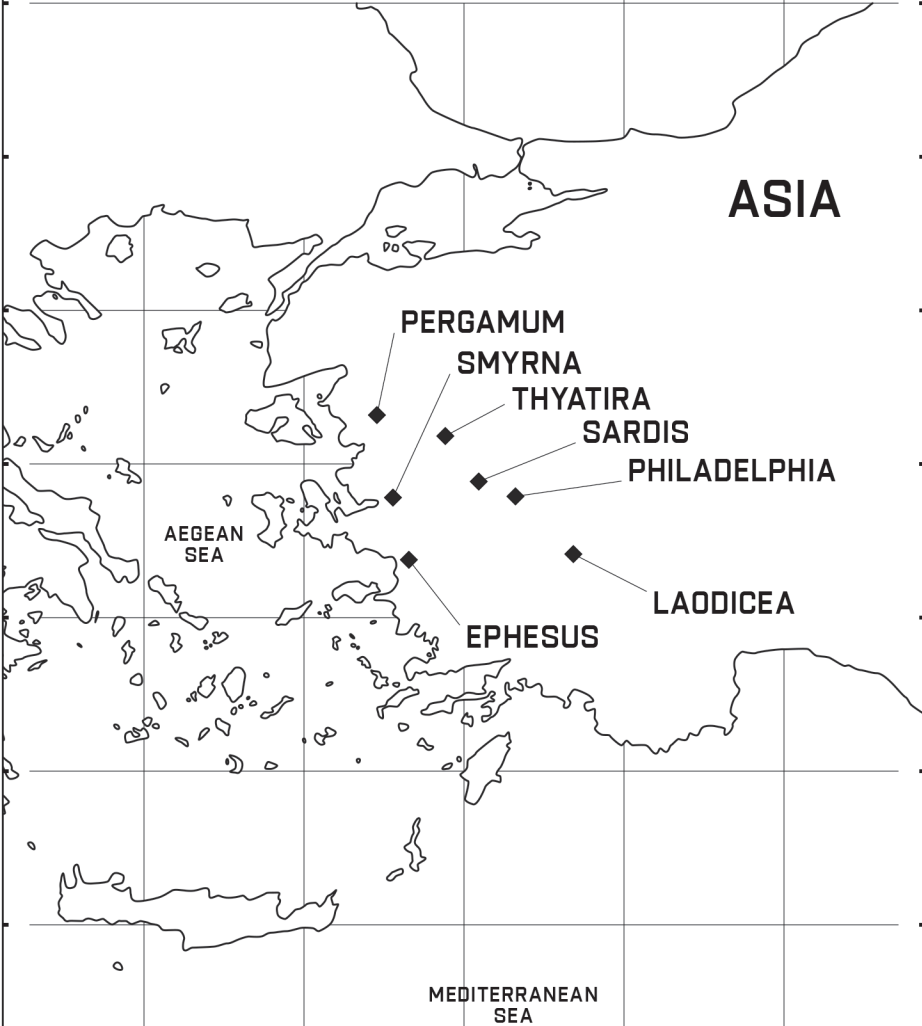

JESUS' LETTERS TO THE SEVEN CHURCHES

Letter #1 to Ephesus [Rev. 2:1-7]: "You have left your first love" (v. 4).

Letter #2 to Smyrna [Rev. 2:8-11]: "Be faithful until death, and I will give you the crown of life" (v. 10).

Letter #3 to Pergamum [Rev. 2:12-17]: "To him who overcomes I will give some of the hidden manna" (v. 17).

Letter #4 to Thyatira [Rev. 2:18-29]: "Hold fast what you have till I come" (v. 25).

Letter #5 to Sardis [Rev. 3:1-6]: "Remember therefore how you have received and heard; hold fast and repent" (v. 3).

Letter #6 to Philadelphia [Rev. 3:7-13]: "I have set before you an open door, and no one can shut it" (v. 8).

Letter #7 to Laodicea [Rev. 3:14-22]: "You are neither cold nor hot. I could wish you were cold or hot" (v. 15).

JESUS' SEVEN STATEMENTS FROM THE CROSS

Last Words #1: "Father, forgive them, for they do not know what they do" [Luke 23:34].

Last Words #2: "Assuredly, I say to you, today you will be with Me in Paradise" [Luke 23:43].

Last Words #3: "Woman, behold your son! . . . Behold your mother!" [John 19:26-27].

Last Words #4: "My God, My God, why have You forsaken Me?" [Matt. 27:46].

Last Words #5: "I thirst!" [John 19:28].

Last Words #6: "It is finished!" [John 19:30].

Last Words #7: "Father, 'into Your hands I commit My spirit'" [Luke 23:46].

JESUS' SEVEN "I AM" STATEMENTS

"I Am" #1: "I am the bread of life. He who comes to Me shall never hunger, and he who believes in Me shall never thirst" [John 6:35].

"I Am" #2: "I am the light of the world. He who follows Me shall not walk in darkness, but have the light of life" [John 8:12].

"I Am" #3 and #4: "I am the door. . . . I am the good shepherd" [John 10:7, 11].

"I Am" #5: "I am the resurrection and the life" [John 11:25].

"I Am" #6: "I am the way, the truth, and the life. No one comes to the Father except through Me" [John 14:6].

"I Am" #7: "I am the vine" [John 15:5].

SO THIS IS WHAT ELEVATORS LOOK LIKE



Crawler carrying Apollo 14 Saturn V on November 9, 1970

NASA; scanned by Kipp Teague

IF NOT ME, ANOTHER

WHERE NEIL, MICHAEL, AND BUZZ LANDED ON THE MOON

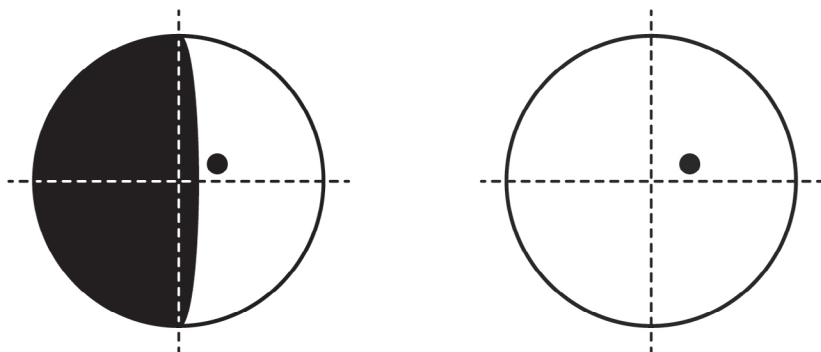

The image on the left shows what the moon looked like from earth on July 16, 1969.

An Jesus said.

"I am the vine, you are
the branches. Whoever remains
in me, and I in him,
will bear much fruit;
for you can do nothing
without me."

Isaiah 40:12

"When I consider thy
heavens, the work of thy
fingers, the moon and the
stars, which thou has
ordained; What is man,
that thou art mindful
of him? and the Son of
Man, that thou visitest
Him?"

Buzz Aldrin wrote Bible verses and prepared comments to guide his remarks for the lunar surface broadcast. His actual words from the moon omitted any references to the Bible or his planned Communion service, as advised by Deke Slayton.

LM OTERO/AP PHOTO



Wernher von Braun, NASA's director of the Marshall Space Flight Center, in his office in Huntsville, Alabama, in 1965 sitting in front of a row of rocket models. Fifth from the left with the red escape tower is a Mercury-Redstone [used by Alan Shepard on the first manned launch by NASA] and the far right is a Saturn V sticking through the ceiling tiles.

ARCHIVE PHOTOS/STRINGER





On September 12, 1962, President John F. Kennedy pledged to put a man on the moon and return him safely home by the end of the decade in a speech at Rice University in Houston, Texas, attended by more than forty thousand people.

NASA



Wernher von Braun explains the launch system to his good friend President John F. Kennedy at Cape Canaveral, Florida. The date is November 16, 1963, six days prior to the president's assassination.

NASA



John F. Kennedy Jr., on his third birthday, stands at salute in front of the casket of his father, President John F. Kennedy. His mother, Jacqueline Kennedy [center], and sister Caroline Kennedy are accompanied by the late president's brothers, Senator Edward Kennedy [left] and Attorney General Bobby Kennedy [right].

NEW YORK DAILY NEWS



Before there were space men there were space monkeys. Ham, NASA's first "astro chimp," was sent into orbit on January 31, 1961.
NASA



Dr. Robert H. Goddard and a liquid-fueled rocket, which was fired on March 16, 1926, in Auburn, Massachusetts. It flew for only 2.5 seconds, climbed to 41 feet, and landed 184 feet away in a cabbage patch. Dr. Goddard has been posthumously considered the father of modern rocketry and an indispensable part of the moon landing.

NASA



Ed White (left), Virgil "Gus" Grissom (center), and Roger Chaffee (right)—the crew of Apollo 1, who perished in a fire on the launchpad during a test on January 27, 1967.

NASA

Aldrin takes the first "space selfie" during extravehicular activities (EVA) on Gemini 12 on November 12, 1966. He set his camera on the edge of the hatch, pointed it in his direction, and took the photo.

NASA





Gleaming white and bathed in light. The Saturn V is the most magnificent and powerful rocket that has ever been launched by man. Hollywood-style spotlights had a stunning effect that only enhanced its mystique. The 363-foot Saturn V was a three-stage vehicle that stood taller than the Statue of Liberty. This picture is from Apollo 8, the first manned flight of the Saturn V.

NASA



The Crawler-Transporter that moved the Saturn V from the Vehicle Assembly Building to the launchpad. You can see a man next to one of the beast's enormous treads. This photo is from Apollo 13.

NASA



With the Apollo 11 Saturn V rocket and mobile launcher on its back, the Crawler-Transporter makes its way out of the Vehicle Assembly Building—the largest single-story building on earth.

NASA



Mission Control in Houston, Texas. The front row was nicknamed "the trench" supposedly because the pneumatic tubes [like what you use at an outside bank deposit] piled up on the ground reminiscent of spent Howitzer casings. The three crews of flight controllers led by a flight director worked in shifts designated by colors; during Apollo 11 the colors were blue, red, and white. Mission Control retires colors the same way professional sports retire numbers.

NASA

Steve Bales at his guidance, navigation, and control station (GNC) at Mission Control Center at Johnson Space Center. Steve was twenty-six years old in a room where the average age was twenty-eight. The decision to land or abort when the program alarm went off during the Apollo 11 mission was left to him.

NASA



For every director you could see there was back-room support you couldn't. The flight dynamics support team is pictured here during Apollo 11. Jack Garman, who knew what the 1202 alarm was in moments, is second from the left.

NASA



Earthrise. One of the most iconic photos of all time. This was the first time the earth was seen from the vantage point of the moon on Apollo 8 in December 1968.

NASA

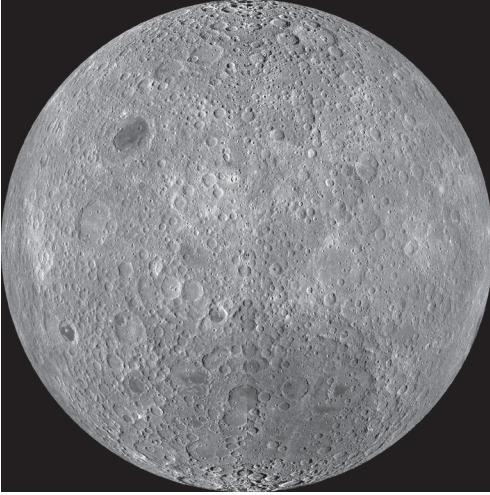

The dark side of the moon, which was seen for the first time by man's eyes on Apollo 8 in December 1968, is far more battered and jagged than the side we see from earth.

NASA

Astronaut Peggy Whitson was the first woman to ever command the International Space Station. She has spent 665 days in space.

NASA



Human computer. NASA mathematician Katherine Johnson at her desk at Langley Research Center in 1966. One of the "hidden figures" of the space program, NASA could never have landed on the moon without the help of many people like Katherine who worked behind the scenes on the orbital mechanics that made spaceflight possible.

NASA

All hands on deck. It took the combined efforts and sacrifice of four hundred thousand people to get from the earth to the moon, including these workers who are assembling the Apollo 1 Module in 1966 in Downey, California.

RALPH MORSE/THE LIFE PICTURE COLLECTION/
SHUTTERSTOCK





Mission patch for Apollo 11. Designed by Michael Collins, it has a bald eagle clutching an olive branch with the moon in the foreground and the earth in the background.

NASA

Apollo mission simulator. Astronauts, engineers, and backup crews spent as much as fourteen hours a day, six days a week practicing. They prepared for hundreds of potential problems thrown at them by Dick Koos, simulation supervisor [SimSup]. William A. Anders, Michael Collins, and Frank Borman [from top of stairs] are about to enter in the photo at the top; in the bottom photo you can see them inside the simulator.

NASA

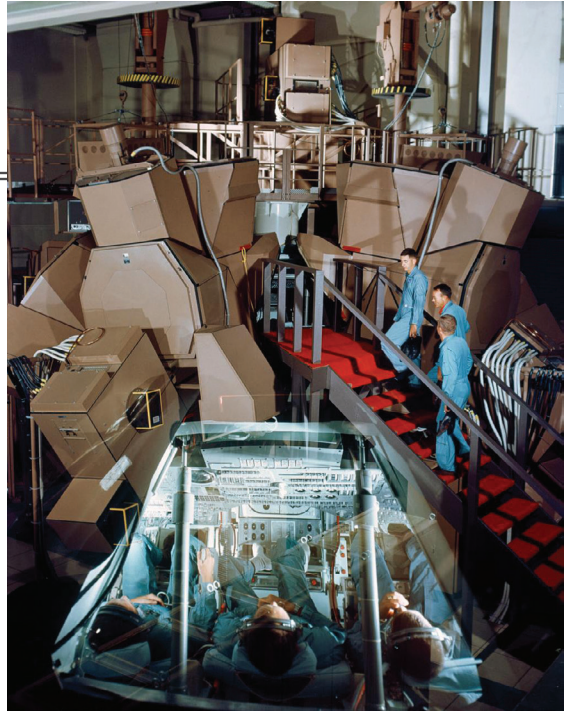

The LLRV [Lunar Landing Research Vehicle] is a machine that simulated the powered descent in the lunar module. It nearly killed Neil Armstrong when he ejected from it seconds before it crashed. Here Armstrong trains for the mission at NASA's Lunar Landing Research Facility.

NASA





Heading to the moon. The Apollo 11 crew and support teams in the hallway of the Manned Spacecraft Operations Building as they head to Launch Complex 39A for the first manned lunar landing mission.

NASA

Liftoff of Apollo 11. Generating 7.7 million pounds of thrust, the Saturn V launch vehicle wears the Apollo spacecraft like a witch's hat as it leaves earth heading for space—going from zero to 17,500 miles per hour in under nine minutes.

NASA

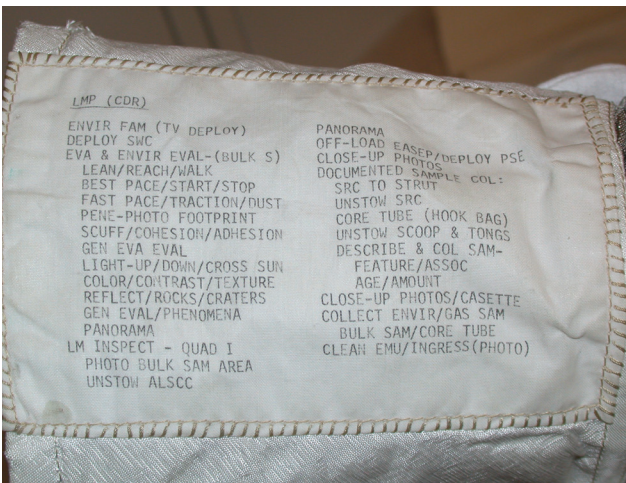

Checklist. Aldrin and Armstrong each had a checklist sewn onto the wrist of their space suit so they never lost sight of all they had to do on the lunar surface. This is Aldrin's checklist.

NASA



A million people flocked to the beaches around Cape Kennedy, Florida, to witness the Apollo 11 launch on July 16, 1969.

RALPH CRANE/THE *LIFE* PICTURE COLLECTION/SHUTTERSTOCK



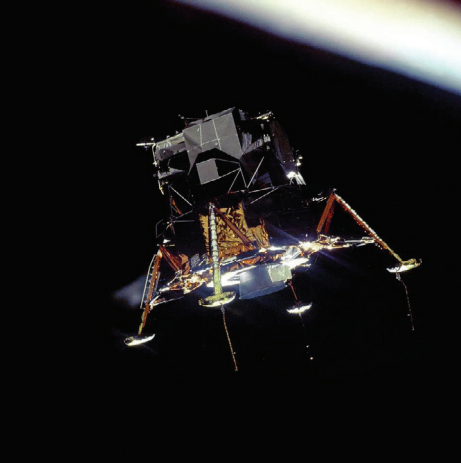

Contact light. The Apollo 11 lunar module, Eagle, photographed by Collins. The long rod-like protrusions under the landing pods are lunar surface sensing probes. Upon contact with the lunar surface, an indicator light told the astronauts to cut the engines. When Jim McDivitt returned from Apollo 9, the lunar module's first manned flight, he sent the manufacturer a note that said: "Many thanks for the funny-looking spacecraft. It sure flies better than it looks."

NASA

Perhaps the most famous photo of the Apollo 11 mission taken as Aldrin posed before the camera, with Armstrong in the reflection of his gold-plated visor, along with the flag and the Eagle.

NASA

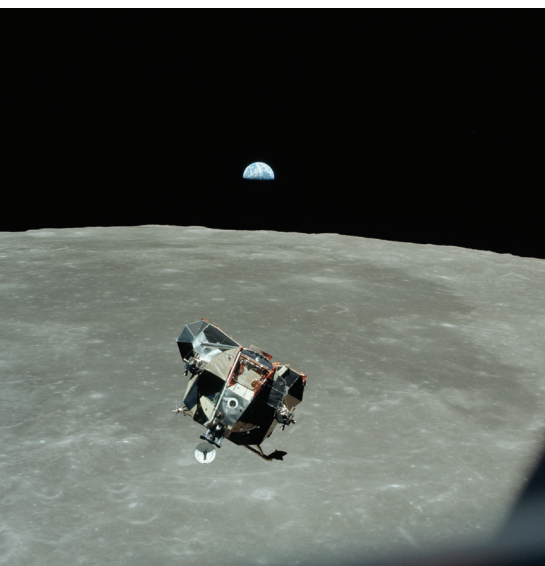
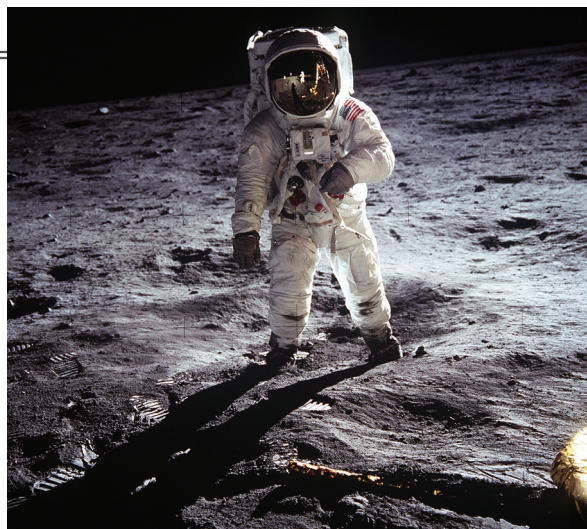

Armstrong and Aldrin return to rendezvous and dock with Columbia after a successful moon landing in the Eagle as Collins looks on. The earth is in the background.

NASA

No normal day. Armstrong is all smiles after a historic small step on the moon. Charts are duct-taped to the wall of the LM Eagle indicating various switch and fuse positions for the controls.

NASA





Space food. The food NASA prepared improved dramatically over the years but was never why anyone became an astronaut. These dehydrated meals were from Project Gemini in 1963.

RALPH MORSE/THE LIFE PICTURE COLLECTION/
SHUTTERSTOCK

Moon car. The Lunar Roving Vehicle (LRV) on the moon during Apollo 17. Built by the Boeing Company, the LRV was light, battery powered, and had a range of fifty-five miles. On this mission the astronauts managed to break a fender and repair it with duct tape.

NASA

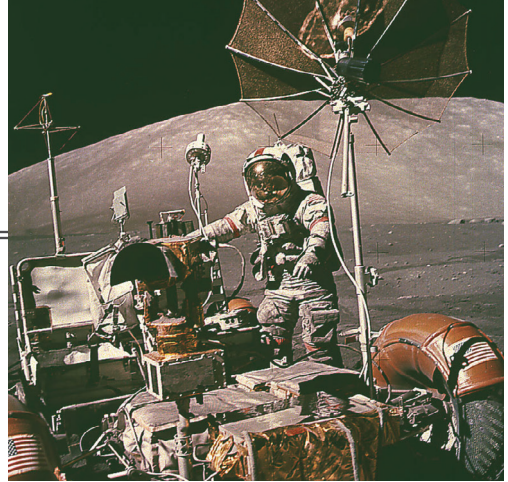

Lunar samples being observed after Apollo 16 by geologists Don Morrison (left), Fred Hörz (right) and William (Bill) Muehlberger (center). The larger rock is the biggest sample ever taken from the moon and is known as "Big Muley."

NASA

This stamp, commemorating the success of Apollo 11, enraged Aldrin's father, who thought it should read "First Men on the Moon."

US POST OFFICE



Astronauts on the International Space Station currently work out for two-plus hours a day to offset the negative effects of microgravity on the human body. Here astronaut Shane Kimbrough does some squats in August 2021.

MEGAN MCARTHUR

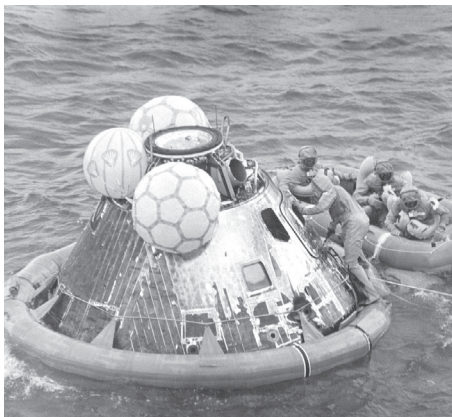

Task completed. On July 24, 1969, after a successful landing on the moon, the Apollo 11 command module Columbia splashed down in the Pacific Ocean and was retrieved by a specially trained recovery team. The astronauts had traveled half-a-million miles in eight days and made it safely home by the end of the decade, as President Kennedy predicted.

NASA

Armstrong, Aldrin, and Collins were kept in quarantine for twenty-one days after they left the lunar surface. In this photo from Hawaii, they are shown reuniting with their wives, Pat Collins, Jan Armstrong, and Joan Aldrin, from the window of the Airstream trailer that would transport them to the quarantine facility in Houston.

NASA



On August 13, 1969, New York City welcomed the Apollo 11 astronauts with a ticker-tape parade down Broadway and Park Avenue in what was, at that point, the largest parade in the city's history.

NASA

Armstrong, Collins, and Aldrin were swarmed by thousands in Mexico City on one stop of their forty-five-day Giant Leap Tour after the moon landing.

NASA

